

 ION Electricals Pvt. Ltd.

OPERATING MANUAL

OF



WEEKLY SETTABLE TIMER

- Make sure you read this operating manual before using the WEEKLY SETTABLE TIMER.
- Store this operating manual safely so that you can use it in future.

Table of Contents

Contents.....	2
1. GETTING STARTED.....	3
KEYBOARD FUNCTIONS:.....	3
DISPLAY MODES:.....	4
2. LEARNING TO OPERATE.....	6
SETTING THE TIME:.....	6
PROGRAMMING THE TIMER.....	7
3. SAMPLE PROGRAMS.....	9
4. TROUBLESHOOTING.....	10
CALIBRATION OF THE CLOCK:.....	11

LIST OF FIGURES 1

Figure 1: Front view of WEEKLY SETTABLE TIMER.....	3
Figure 2: Back view of WEEKLY SETTABLE TIMER.....	5

1. GETTING STARTED

THIS SECTION MAKES YOU FAMILIAR WITH OUR **WEEKLY SETTABLE TIMER**.

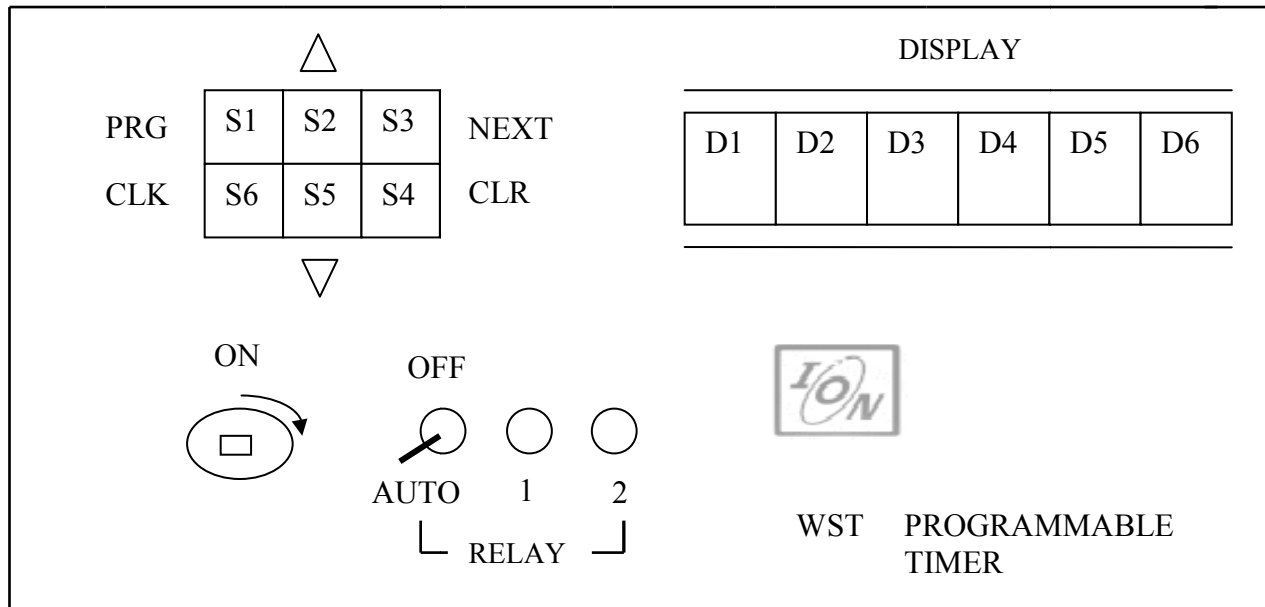

Figure 1: Front view of **WEEKLY SETTABLE TIMER**

KEYBOARD FUNCTIONS:

Key	Marking	Function
S1	PRG	Program setting is enabled
S2	△	Increments the flashing number
S3	NEXT/DATE	Selects number to be set/Sets “Calendar” display mode
S4	CLR/SEC	Clears the setting/Sets Seconds display mode
S5	▽	Decrements the flashing number
S6	CLK	Clock setting is enabled

OFF/AUTO SWITCH: This switch is used to keep the relays “OFF” manually. In “AUTO” position, the relays will operate automatically as per the program setting.

RELAY ON INDICATOR LAMPS: These LED lamps glow, when the respective Relay is energized.

DISPLAY MODES:

MODES	DIGIT(LEFT TO RIGHT)					
	D1	D2	D3	D4	D5	D6
1	DAY		HOURS		MINUTES	
2	YEAR DAY		MONTH HOURS		DATE MINUTES	
3	HOURS		MINUTES		SECONDS	

Mode 1: This is normal mode. “Day, Hours: Minutes” are displayed. Method of returning to this mode is described below.

Mode 2: “Hours: Minutes” & the “Year: Month: Date” flash alternately. The display reads “Hours: Minutes” for about 10 seconds & “Year: Month: Date” for a second. To set this mode ensures that the display is in normal mode. Push S3, keeping “S3” pushed, press “S2” to select the data given below.

DATA	FUNCTION
12	Slave output in 12 Hours format
12A	Slave output in 12 Hours format + Time/Date alternate flashing
24	Slave output in 24 Hours format
24A	Slave output in 24 Hours format + Time/Date alternate flashing

Mode 3: Push S4 for about 2 seconds. Hours.Minutes.Seconds are displayed. To get back to the previous mode, press S4 for about 2 seconds.

SLAVE DISPLAY : The real time data is provided for driving model “WSS” Slave display units. To connect these, a socket marked “SLAVE OUT” is provided on the backside. Read Troubleshooting before installing slave display.

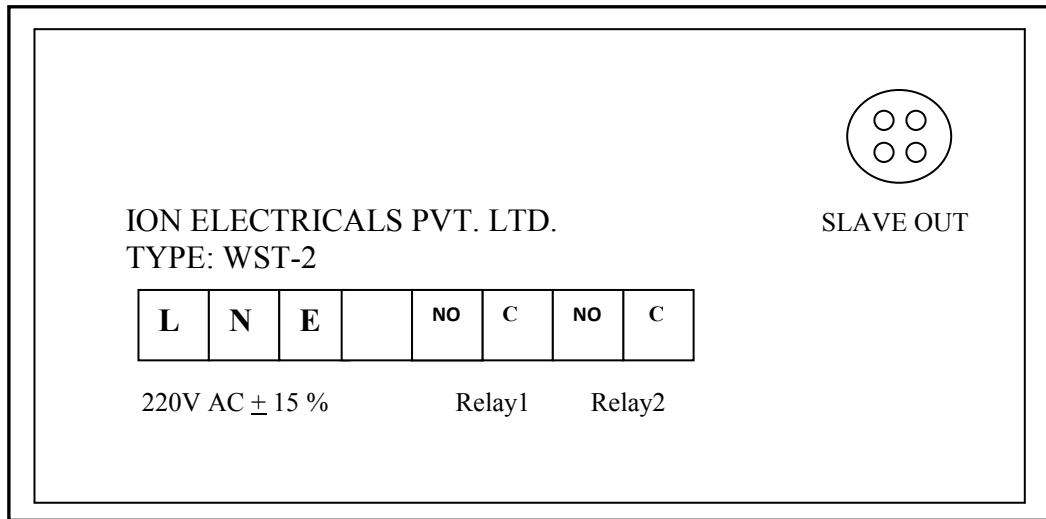

Figure 2: Back view of WEEKLY SETTABLE TIMER.

- WEEKLY SETTABLE TIMER is capable of driving slave clocks. To connect these, a socket marked “**SLAVE OUT**” is provided.
- As shown in the figure 2 ,two relays RELAY 1 & RELAY 2 are provided. To sound siren and lecture bells as per the scheduled time, they can be connected between the NO & C terminals of the relay.

2. LEARNING TO OPERATE

SETTING THE TIME:

Push “S3” till all digits start flashing. This is the Time Setting Mode. It allows the user to set the Year, Month, Day & Hours & Minutes.

For example, let us set “1989 May 16, Tuesday, 2:30 P.M”.

Year: Press “S3”.D1 & D2 flashes showing a number from 0 to 99. Press “S2” or “S5” to set the year, in this case “89”.

Month: Press “S3”.D3 & D4 flashes showing a number from 1 to 12. Press “S2” or “S5” to set the month, in this case “5”i.e May.

Date: Press “S3”.D5 & D6 flashes showing a number from 1 to 31. Press “S2” or “S5” to set the date, in this case “16”.

Day: Press “S3”.D1 flashes. Press “S2” or “S5” to set the current day of the week, as “1” for Monday, “2” for Tuesday and so on “7”for Sunday. In this case set the day to “2” for Tuesday.

Hours: Press “S3”.D3 & D4 flashes. Press “S2” or “S5” to set the Hours in 24 Hours format, i.e from 0 to 23. In this case “14” for 2 P.M.

Minutes: Press “S3”.D5 & D6 flashes. Press “S2” or “S5” to set the Minutes from 0 to 59.In this case “30”.

*Press “S6” to go to enter the new setting. The display returns to normal mode & the seconds resets to zero.

If the unit is left in setting mode for more than one minute, the display returns to the normal mode automatically. If any changes were made, they are not registered.

Resetting the seconds: Push “S6”. All digit will start flashing. Push “S6” once again. Seconds reset to “00” without changing any other setting. This is useful for synchronizing the timer with a known “STANDARD” time.

PROGRAMMING THE TIMER:

Fifty programs can be stored. Step by step procedure for setting or editing a program is given in this section. Keep this note handy while you follow the steps (1) to (9) below. Ensure that the timer is in the normal display mode. (It is not in the time setting mode). As soon as you enter the programming mode in step (1) below, both the relays are switched OFF. External “Manual Switch” should be provided for each relay, if you want to keep the respective output ON, while programming.

1. Push “S1”.D1 shows “P” and D2 flashes. Set D2 using “S2” or “S5” to select the desired program (0 to 49).If D3 to D6 show ‘-----’, it means that the program is deactivated. Activating the program is explained in (9).To examine or modify the program settings, to through steps (2) to (8). Press “S3”.
2. Now D1 shows “d” & D2 flashes. Use “S2” , “S5” to set D2 for selecting the Day(s) for operation :

D2	Day(s) of operation
0	Every day
1	Every Monday
2	Every Tuesday
3	Every Wednesday
4	Every Thursday
5	Every Friday
6	Every Saturday
7	Every Sunday
8	Every day except Monday
9	Every day except Tuesday
A	Every day except Wednesday
B	Every day except Thursday
C	Every day except Friday
D	Every day except Saturday
E	Every day except Sunday
F	Every day except Saturday & Sunday

After setting the day(s) of operation, press “S3”.

3. D1 now indicates “r”.D2 flashes to indicate the output type.

D2	Output type
1	Relay 1 Continuous
2	Relay 2 Continuous
3	Relay 1 & Buzzer
4	Relay 2 & Buzzer
5	Buzzer
6	Relay 1 interrupted
7	Relay 2 interrupted

Use “S2” & “S5” to select the desired output type. Press “S3”.

4. D3, D4 flashes. Use “S2” or “S5” to set the “Hours” to the time at which output should operate, press “S3”.
5. D5, D6 flashes. Use “S2” or “S5” to set the “Minutes” to the time at which output should operate, press “S3”.
6. D1 flashes a symbol “o” or “h”. This identifies the “ON” duration range for the output which is user selectable.

D1 D2	D3	D4 D5 D6	
o	*	--Hr---- ----Mt--	Time at which the output will cut off
h	*	--Mt--- ----Sec--	“ON” duration of the output. (Max. 59M 59S)

* is 1 to 7 (indicates the output type selected in {3} above).

Use “S2” or “S5” to select “o” or “h”. Press S3.

7. D3, D4 flashes. Use “S2” or “S5” to set the “Hours” if the choice in (6) is “o”. If “h” was chosen in (6), then you’re setting the “Minutes”. Press “S3”.
8. D3, D4 flashes. Use “S2” or “S5” to set the “Minutes” if the choice in (6) is “o”. If “h” was chosen in (6), then you’re setting the “Seconds”. Press “S3”.
9. The display returns to the condition in (1). “----” at D3 to D6 means that the program is deactivated. To activate the program, push “S1” immediately. D3 to D6 will display the time set in steps (4) & (5) above. To deactivate the program, push “S4”.

At this stage, you may change the program number to store or edit more programs or press “S6” to return to the normal mode.

3. SAMPLE PROGRAMS

Ex. 1: Set program no. “P3” to operate Relay 1 and Buzzer at 7:15 am for the period of 15 seconds on Every day Except Sunday.

1. Push S1. D1 shows “P” and D2 flashes. Set D1, D2 to “P3” using S2 or S5. Press S4 to De-activate the program so that D3 to D6 read “-----”. Press S3.
2. Now, D1 shows “d” and D2 flashes. Using S2 or S5 set D2 to “E” for selecting the operation Days as “Every day Except Sunday” .Press S3.
3. D1 now indicates “r”.Using S2 or S5 set D2 to “3” for selecting Relay 1 as the desired output. Press S3.
4. D3, D4 flashes. Use S2 or S5 to set the “Hours” to “7”.Press S3.
5. D5, D6 flashes. Use S2 or S5 to set the “Minutes” to “15”.Press S3.
6. D1 flashes a symbol “o” or “h”. As the desired ON duration is less than an hour, use S2 or S5 to select “h”. Press S3.
7. D3, D4 flashes. Use S2 or S5 to set the “Minutes” to “00”.Press S3.
8. D5, D6 flashes. Use S2 or S5 to set the “Seconds” to “15”.Press S3.
9. The display returns to the condition in (1).Press S1 to activate the program. D3 to D4 will read 7.15. Press S3.

Ex. 2: Set program no. “n3”, to operate Relay 1(Interrupt operation) at 8.30 am for 20 seconds every day.

1. Push S1. D1 shows “P” and D2 flashes .Set D1,D2 to “n3” using S2 or S5.Press S4 to de-activate the program so that D3 to D6 read “-----”. Press S3.
2. Now, D1 shows “d” and D2 flashes. Using S2 or S5 set D2 to “o” for selecting the operation Day(s) as “Every day”. Press S3.
3. D1 now indicates “r”. Using S2 or S5 set D2 to “6” for selecting “Relay 1 (interrupted) and buzzer” as the desired output. Press S3.
4. D3, D4 flashes. Use S2 or S5 to set the “Hours” to “8”.Press S3.
5. D5, D6 flashes. Use S2 or S5 to set the “Minutes” to “30”.Press S3.
6. D1 flashes a symbol “o” or “h” .As the desired ON duration is less than an hour, use S2 or S5 to select “h”. Press S3.
7. D3, D4 flashes. Use S2 or S5 to set the “Minutes” to “00”.Press S3.
8. D5, D6 flashes. Use S2 or S5 to set the “Seconds” to “12”.Press S3.
9. The display returns to the condition in (1). Press S1 to activate the program. D3, D4 will read 17.30. Press S6.

Ex. 3: De-activate program no. 3 stored in Ex. 1 above. This is accomplished in just one step.

1. Push S1. D1 shows “P” and D2 flashes. Set D1, D2 to “P3” using S2 or S5, D3 to D6 show 7.15. Press S4.D3 to D6 reads “-----”. Press S6.

4. TROUBLESHOOTING

The following will help users to overcome minor problems with the timer or slave display. Before calling ION, please check the “Faults & Remedies” listed below.

Display shows freak readings: If in normal mode, carry out the time setting procedure. If in program mode, to make the freak digit(s) flash press S6.

Relays do not operate as per a particular program: Select that program in the program setting mode and check if the decimal point of D6 is ON.

Relays operates when it is not expected to: Press S1 to enter program setting mode and check all programs to verify that the undesired ones are de-activated.

Display is Blank: Switch OFF the mains supply to the timer momentarily and switch it “ON” again.

Flickering in slave display: Check for loose connection. Check that all connections are hard soldered to ensure good contact. See that all data line cables have shield & proper earthing is connected.

Calibration: If the clock is fast or slow with reference timing , do the calibration procedure as given below.

CALIBRATION OF THE CLOCK:

Select the display to mode 3 (seconds mode). Push "S3". D3 & D4 displays the calibration figure. Keeping "S3" pushed, Pushed "S2" to select the desire value as per the chart.

Note: Do not touch or handle data line connections without switching off the master & buffer unit.

Calibration Chart:

-VE Calibration	Seconds Per day	+VE Calibration	Seconds per day
00	0	20	0
01	-0.05	21	0.10
02	-0.14	22	0.28
03	-0.23	23	0.46
04	-0.32	24	0.64
05	-0.41	25	0.82
06	-0.50	26	1.00
07	-0.59	27	1.18
08	-0.68	28	1.36
09	-0.77	29	1.54
0A	-0.86	2A	1.72
0b	-0.95	2b	1.90
0C	-1.04	2C	2.08
0D	-1.13	2D	2.26
0E	-1.22	2E	2.44
0F	-1.31	2F	2.62
10	-1.40	30	2.80
11	-1.49	31	2.98
12	-1.58	32	3.16
13	-1.67	33	3.34
14	-1.76	34	3.52
15	-1.85	35	3.70
16	-1.94	36	3.88
17	-2.03	37	4.06
18	-2.12	38	4.24
19	-2.21	39	4.42
1A	-2.30	3A	4.60
1b	-2.39	3b	4.78
1C	-2.48	3C	4.96
1d	-2.57	3d	5.14
1E	-2.66	3E	5.32
1F	-2.75	3F	5.50